

Product information:

The SP series are high efficiency sound projectors designed to provide good speech intelligibility and background music in a wide variation of applications. They are all weather-proof treated to be used indoor as well as outdoor and are perfect suited to be used in large 100V broadcast systems such as train stations or airports. They all meet the IP56 Ingress Protection standard. The SP20 is a high-efficiency sound projector with an RMS power of 20 Watt, designed to provide good speech intelligibility and background music in a wide variation of applications. It is fitted with a 5" broadband loudspeaker and the power is adjustable by the integrated 100V line transformer with power taps for 20 Watt, 10 Watt, 5 Watt and 2.5 Watt at 100 Volt. The speaker can be easily mounted to any wall or ceiling by using the stainless steel mounting bracket. Thanks to the weatherproof treated ABS housing with white or cream weatherproof coated aluminum grill, the speaker has a IP rating of 56 whereby it can be used indoor as well as outdoor for a wide variation of applications.



Applications:

- Government facilities
- Retail
- Corporate



Certification:

 IP56

Properties:

 Weatherproof

Voltage:

 100 Volt

System specifications:

Program power handling		40 W
RMS/AES power handling		20 W
Line Transformer Tappings	1	20 W / 500 Ω
	2	10 W / 1000 Ω
	3	5 W / 2000 Ω
	4	2.5 W / 4000 Ω
Frequency	Response (\pm 3 dB)	130 Hz - 15 kHz
Sensitivity (1W/1m)		92 dB
Sound Pressure (Max. W/1m)		104 dB
Impedance		8 Ω
Dispersion		180°
Directivity Q factor		2.60
Ingress Protection rating		IP56
Connectors		75 cm connection cable
Drivers		5"
Peak power handling		80 W

Product Features:

Dimensions		138 x 204 mm (\varnothing x D)
Weight		1.900 kg
Operating temperature		-20 °C ~ 60 °C
Construction		ABS
Mounting		Stainless steel U bracket
Front finish		Aluminium grill
Colours		White
		Beige (SP20/C)
Accessories	Included	Mounting bracket

Variants:

- SP20 - White version
- SP20/C - Cream/Beige version

Shipping & Ordering:

Packaging	Cardboard box
Shipping weight	2.500 kg

Architects' and Engineers' Specifications:

The SP series shall consist of high efficiency sound projectors designed to provide good speech intelligibility and background music in a wide variety of applications. All of them shall be weather-proof treated meeting the IP56 Ingress Protection standard, allowing them to be used in both indoor and outdoor applications. The SP20 shall be a 20 Watt sound projector, fitted with a 5" broadband driver and a 100V line transformer with different power tapplings for 20 Watt, 10 Watt, 5 Watt and 2,5 Watt. The speaker shall be easily mountable to any wall or ceiling using a stainless steel mounting bracket. By using the weatherproof treated ABS housing combined with a white or cream weatherproof coated aluminum grill the speaker shall meet the requirements for an Ingress Protection of IP56. The ABS housing shall be UV resistant and equipped with a 75 cm connection cable. The speaker shall have a power handling of 20 Watt RMS and a maximum power handling of 40 Watt, it shall have a sensitivity of 92 dB when measuring with an input signal of 1 Watt at a distance of 1 meter, while the maximum sound pressure shall be 104 dB. The frequency response (-3 dB) shall range from 130 Hz to 15 kHz. The speaker shall have a diameter of 138 mm and a depth of 204 mm, the weight shall not exceed 2,22kg.

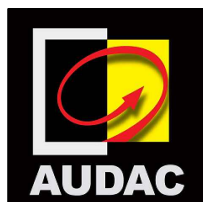
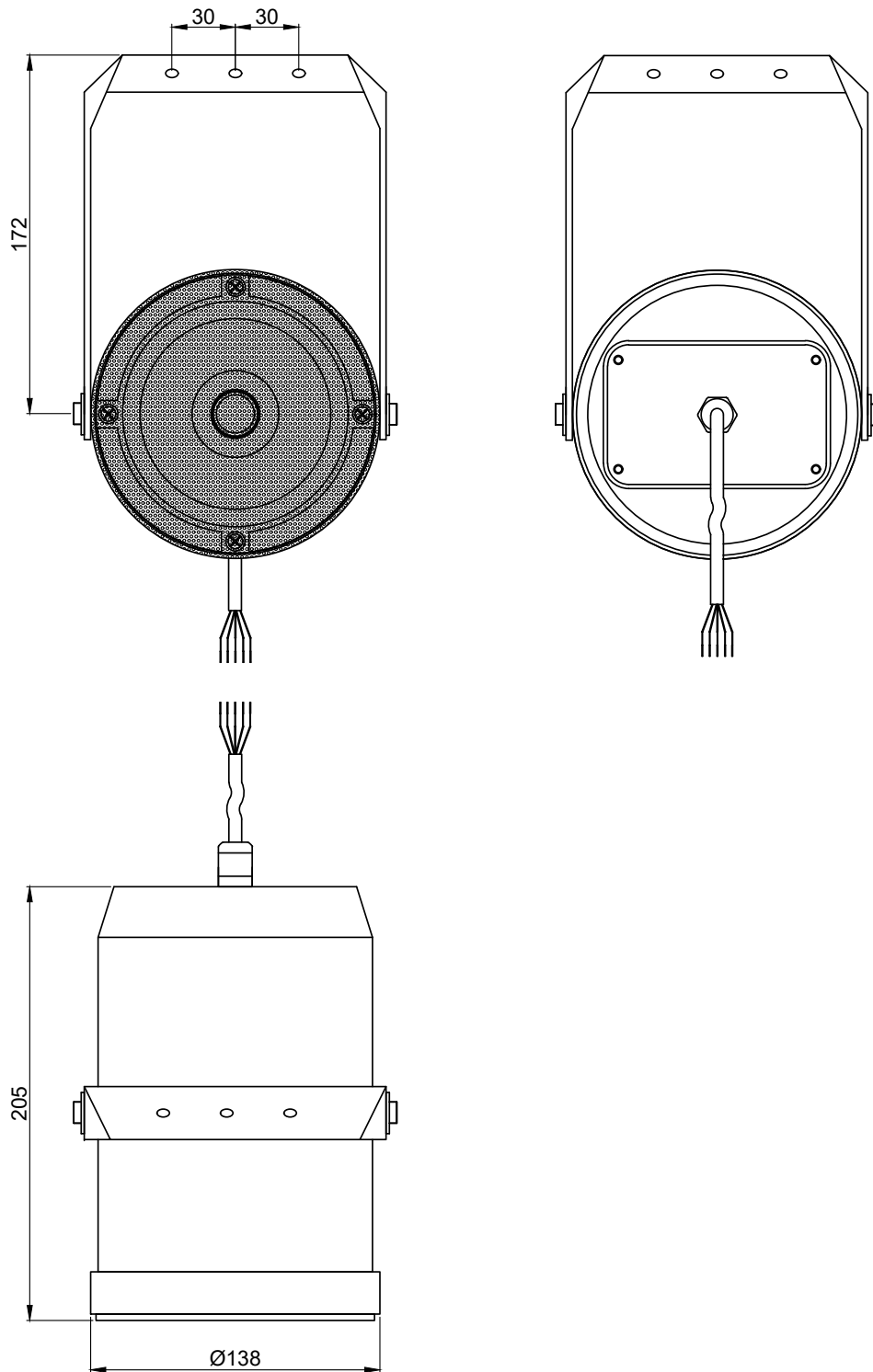

SP20

Product description:
BROADBAND SOUND PROJECTOR 20W 100V

Weight:

1,43 kg

Outer dimensions:
(w x h x d)

Ø138 x 205

Unit height:

N/A